



ZTU Module Datasheet

Version: 20210602

Contents

1	Overview	2
1.1	Features	2
1.2	Applications	2
1.3	Change history	2
2	Module interfaces	3
2.1	Dimensions and package	3
2.2	Pin definition	5
3	Electrical parameters	9
3.1	Absolute electrical parameters	9
3.2	Normal working conditions	9
3.3	TX and RX Power Consumption	10
3.4	Working current	10
4	RF parameters	11
4.1	Basic RF features	11
4.2	TX performance	11
4.3	RX performance	12
5	Antenna	13
5.1	Antenna type	13
5.2	Antenna interference reduction	13
6	Packaging information and production instructions	14
6.1	Mechanical dimensions	14
6.2	Side view	16
6.3	The schematic diagram of a packaging	17
6.4	Diagram of PCB packaging-pin header	17
6.5	Production instructions	19
6.6	Recommended oven temperature curve	21
6.7	Storage conditions	23
7	MOQ and packaging information	24

8 Appendix: Statement

24



ZTU is a low-power embedded Zigbee module that Tuya has developed. It consists of a highly integrated RF processing chip (Z2), a few peripherals, a built-in 802.15.4 PHYMAC Zigbee network protocol stack, and rich library functions. ZTU is embedded with a low-power 32-bit CPU, 1-MB flash program memory, 64-KB RAM, and abundant peripheral resources.

1 Overview

ZTU is a FreeRTOS platform that integrates all function libraries of the Zigbee MAC and TCP/IP protocols. You can develop embedded Zigbee products as required.

1.1 Features

- Embedded with a low-power 32-bit CPU processor
- The maximum clock rate: 48 MHz
- Wide working voltage: 1.8 to 3.6 V
- Peripherals: 15 general-purpose input/output (GPIO), 1 universal asynchronous receiver/transmitter (UART), and 2 analog-to-digital converters (ADC)
- Zigbee connectivity
 - Support 802.15.4 MAC/PHY
 - Working channels 11 to 26 @2.400 to 2.483 GHz, air interface rate: 250 Kbps
 - Up to +10dBm output power and dynamic output power > 35 dB
 - The terminal equipment connects to the network actively.
 - Built-in onboard PCB antenna, IPEX connector reserved
 - Onboard PCB antenna with a gain of 1.08 dBi
 - Working temperature: -40°C to 105°C
 - Support hardware encryption and AES 128

1.2 Applications

- Intelligent building
- Smart household and home appliances
- Smart socket and light
- Industrial wireless control
- Baby monitor
- Network camera
- Intelligent bus

1.3 Change history

Update date	Updated content	Version after update
11/24/2020	This is the first release.	V1.0.0

2 Module interfaces

2.1 Dimensions and package

ZTU has 3 rows of pins with a 1.4 ± 0.1 mm pin spacing.

The ZTU dimensions are 20.3 ± 0.35 mm (W) \times 15.8 ± 0.35 mm (L) \times 3 ± 0.15 mm (H).

The dimensions of ZTU are as follows:

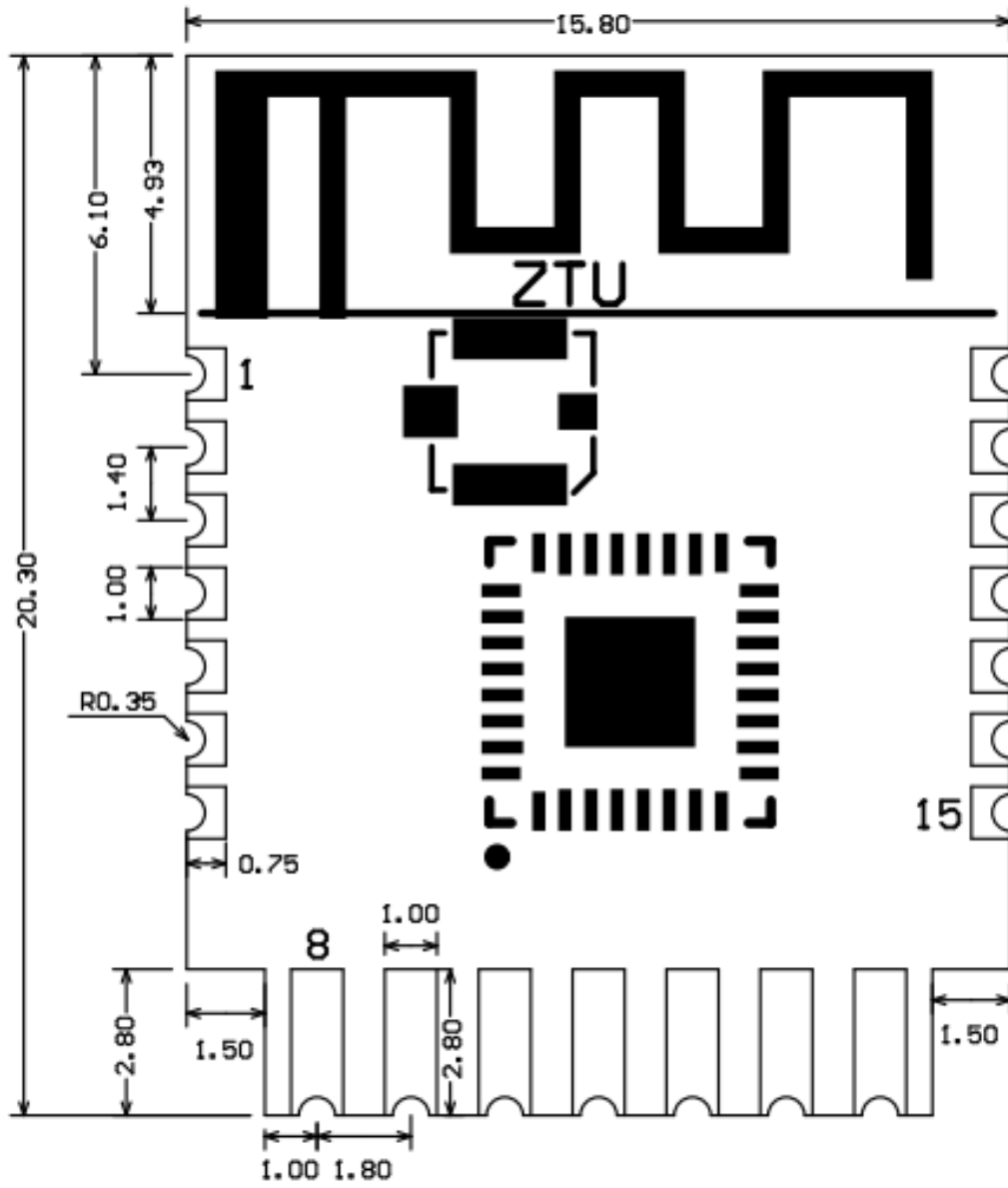

2.2 Pin definition

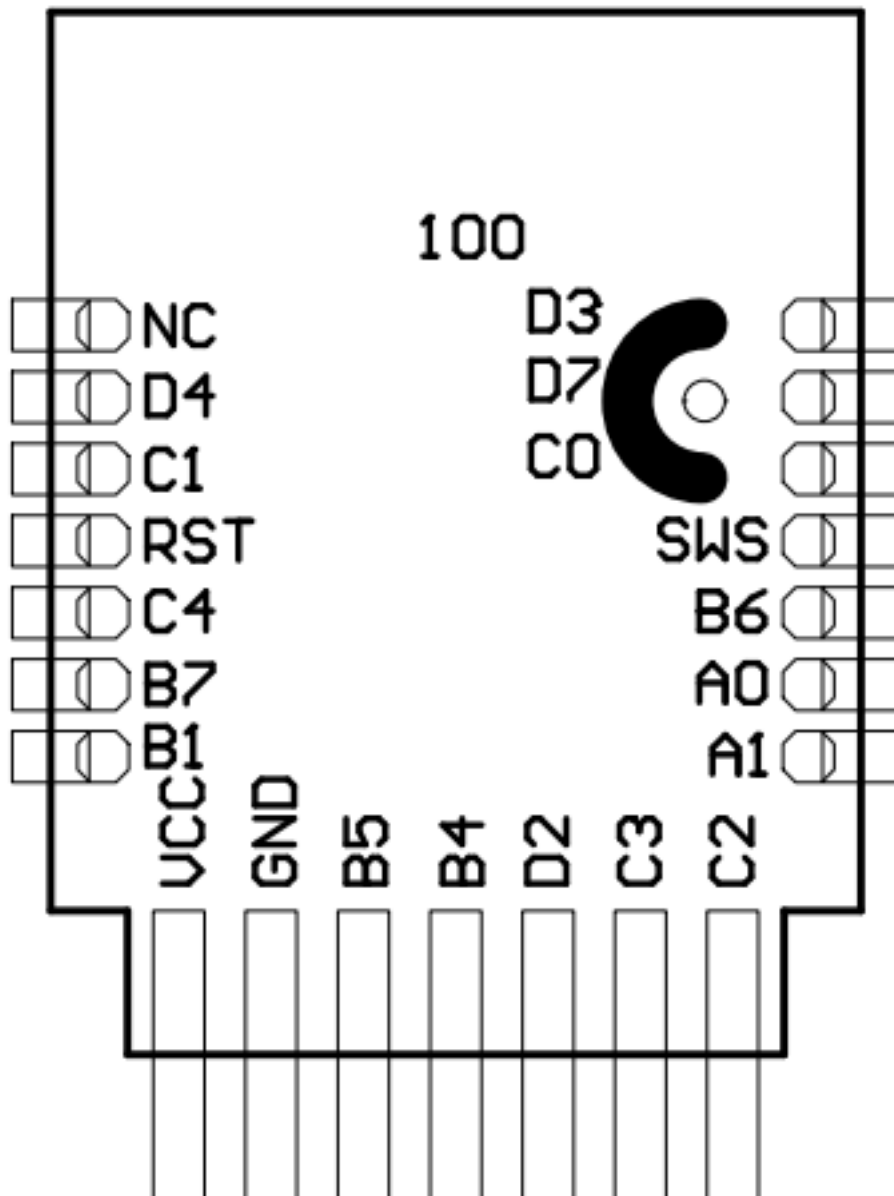

Pin number	Symbol	I/O type	Function
1	D3	I/O	Common I/O pin, which corresponds to D3 (Pin 32) of IC

Pin number	Symbol	I/O type	Function
2	D7	I/O	Common I/O pin, which corresponds to D7 (Pin 2) of IC
3	C0	I/O	Common I/O pin, which corresponds to C0 (Pin 20) of IC
4	SWS	I/O	Burning pin, which corresponds to SWS (Pin 5) of IC
5	B6	I/O	ADC pin, which corresponds to B6 (Pin 16) of IC
6	A0	I/O	Common I/O pin, which corresponds to A0 (Pin 3) of IC
7	A1	I/O	Common I/O pin, which corresponds to A1 (Pin 4) of IC
8	C2	I/O	Support hardware PWM and correspond to C2 (Pin 22) on the internal IC
9	C3	I/O	Support hardware PWM and correspond to C3 (Pin 23) on the internal IC

Pin number	Symbol	I/O type	Function
10	D2	I/O	Support hardware PWM and correspond to D2 (Pin 31) on the internal IC
11	B4	I/O	Support hardware PWM and correspond to B4 (Pin 14) on the internal IC
12	B5	I/O	Support hardware PWM and correspond to B5 (Pin 15) on the internal IC
13	GND	P	Power supply reference ground
14	VCC	P	Power supply pin (3.3V)
15	B1	I/O	Uart_TXD, which corresponds to B1 (Pin 6) of IC
16	B7	I/O	Uart_RXD, which corresponds to B7 (Pin 17) of IC
17	C4	I/O	ADC pin, which corresponds to C4 (Pin 16) of IC
18	RST	I/O	Reset pin, active low

Pin number	Symbol	I/O type	Function
19	C1	I/O	Common I/O pin, which corresponds to C1 (Pin 21) of IC
20	D4	I/O	Common I/O pin, which corresponds to D4 (Pin 1) of IC
21	NC	I/O	No connection

Note: P indicates a power supply pin and I/O indicates an input/output pin.

3 Electrical parameters

3.1 Absolute electrical parameters

Parameter	Description	Minimum value	Maximum value	Unit
Ta	Working temperature	-40	105	°C
VBAT	Power supply voltage	1.8	3.6	V
Static electricity discharge voltage (human body model)	TAMB-25°C	-	2	KV
Static electricity discharge voltage (machine model)	TAMB-25°C	-	0.5	KV

3.2 Normal working conditions

Parameter	Description	Minimum value	Typical value	Maximum value	Unit
Ta	Working temperature	-40	-	105	°C
VCC	Working voltage	1.8	3.3	3.6	V

Parameter	Description	Minimum value	Typical value	Maximum value	Unit
VIL	I/O low-level input	-	-	VDD*0.3	V
VIH	I/O high-level input	VDD*0.7	-	-	V
VOL	I/O low-level output	-	-	VDD*0.2	V
VOH	I/O high-level output	VDD*0.8	-	-	V

3.3 TX and RX Power Consumption

Working status	Mode	Rate	Transmit power/receive	Average value	Peak value (Typical value)	Unit
Transmit	-	250Kbps	+0 dBm	4.64	4.73	mA
Transmit	-	250Kbps	+10 dBm	8.9	9	mA
Receive	-	250Kbps	Constantly receive	6.9	7	mA

3.4 Working current

Working mode	Working status, Ta = 25°C	Average value	Maximum value (Typical value)	Unit
Quick network connection state	The module is in the fast network connection state	9.5	13.5	mA
Network connection state	The module is connected to the network	8.9	10.5	mA
Deep sleep mode	Deep sleep mode, reserve 32KB SRAM	1.4	-	uA

4 RF parameters

4.1 Basic RF features

Parameter	Description
Working frequency	2.405 to 2.480 GHz
Zigbee standard	IEEE 802.15.4
Data transmission rate	250 Kbps
Antenna type	PCB antenna with a gain of 1.08 dBi, IPEX optional

4.2 TX performance

TX performance

Parameter	Minimum value	Typical value	Maximum value	Unit
Maximum output power (250 Kbps)	-	10	-	dBm
Minimum output power (250 Kbps)	-	-25	-	dBm
Output power adjustment stepping	-	0.5	1	dBm
Output spectrum adjacent channel suppression	-	-31	-	dBc
Frequency error	-10	-	10	ppm

4.3 RX performance

RX sensitivity:

Parameter	Minimum value	Typical value	Maximum value	Unit
PER<8%, RX sensitivity (250 Kbps)	-102	-101	-99	dBm

5 Antenna

5.1 Antenna type

ZTU uses only an onboard PCB antenna and uses the IPEX antenna in the ZTU-IPEX module.

5.2 Antenna interference reduction

To ensure the optimal Zigbee performance when the Zigbee module uses an onboard PCB antenna, it is recommended that the antenna be at least 15 mm away from other metal parts.

To prevent an adverse impact on the antenna radiation performance, avoid copper or traces along the antenna area on the PCB.

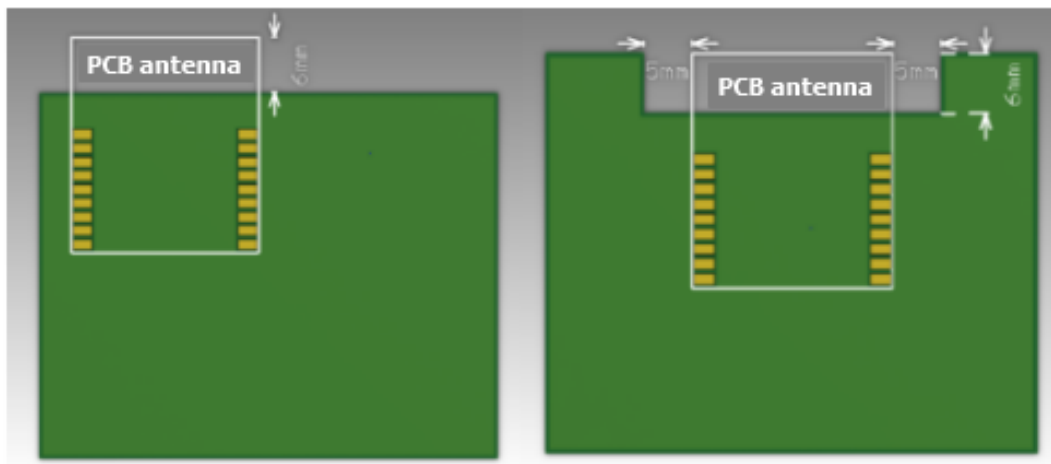

6 Packaging information and production instructions

6.1 Mechanical dimensions

The PCB dimensions are 20.3 ± 0.35 mm (L) \times 15.8 ± 0.35 mm (W) \times 3 ± 0.15 mm (H).

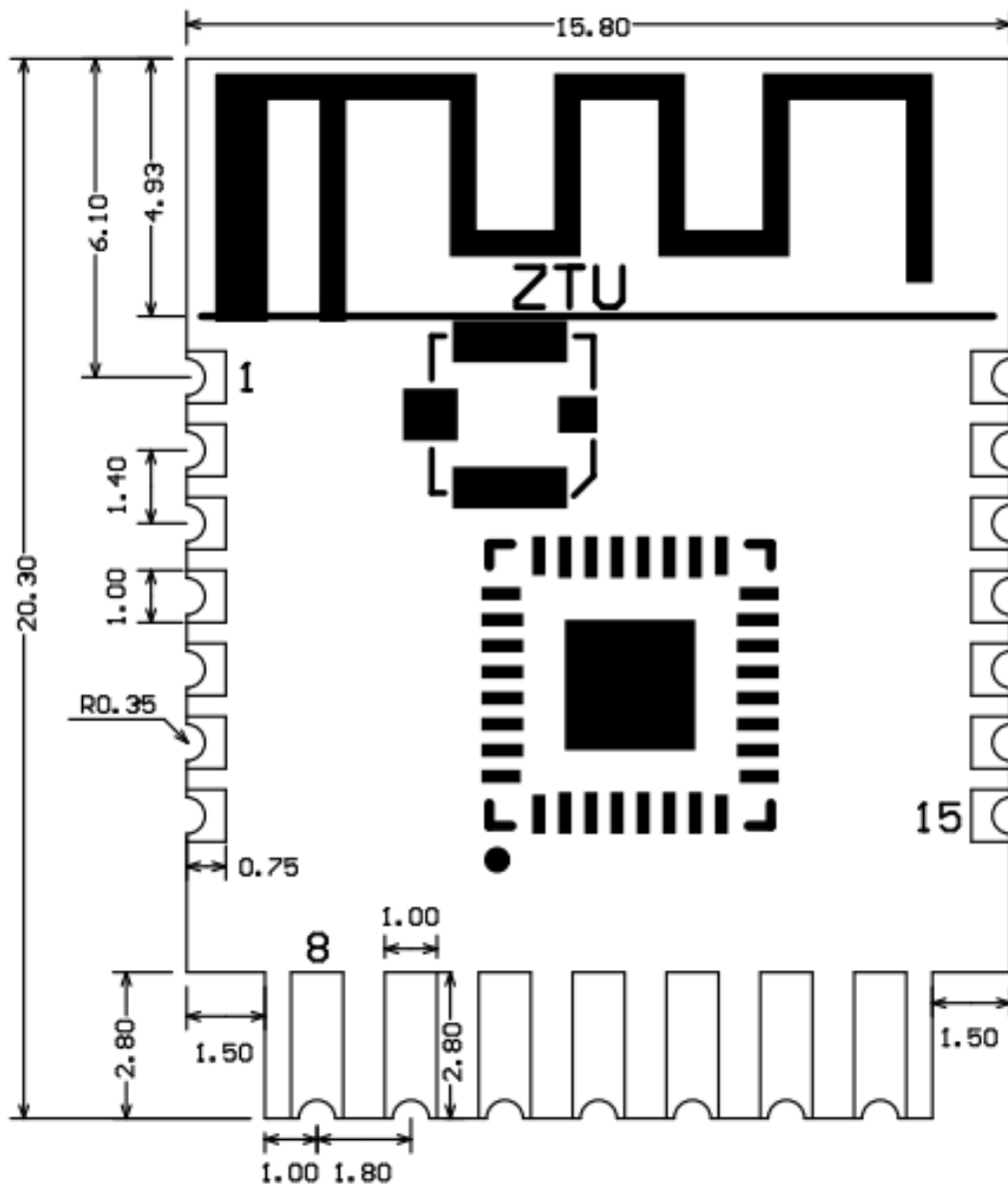

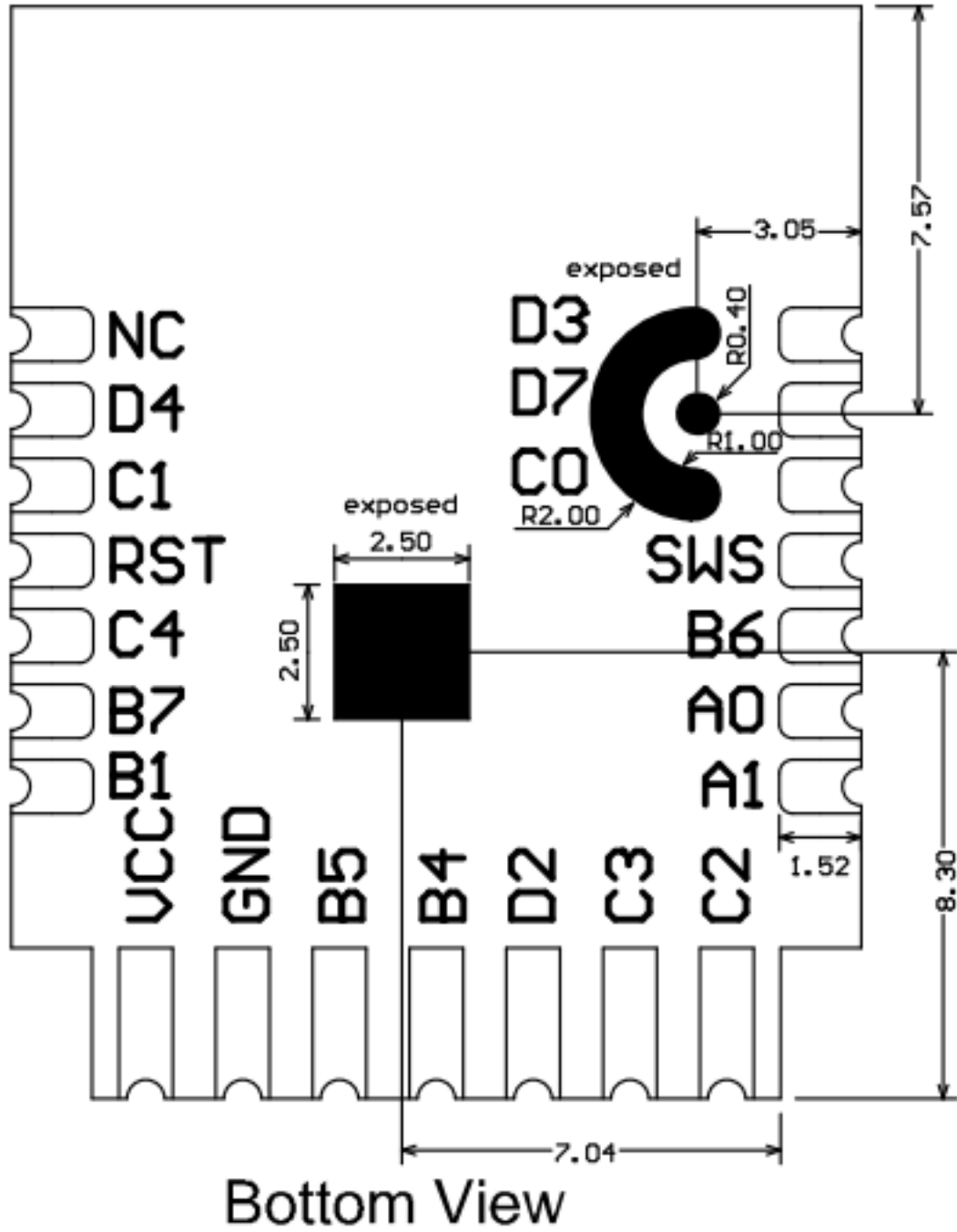

6.2 Side view



Unit: mm

Module form factor tolerance: $\pm 0.3\text{mm}$

Plate thickness tolerance: $\pm 0.1\text{mm}$

Shield cover height tolerance: $\pm 0.05\text{mm}$

6.3 The schematic diagram of a packaging

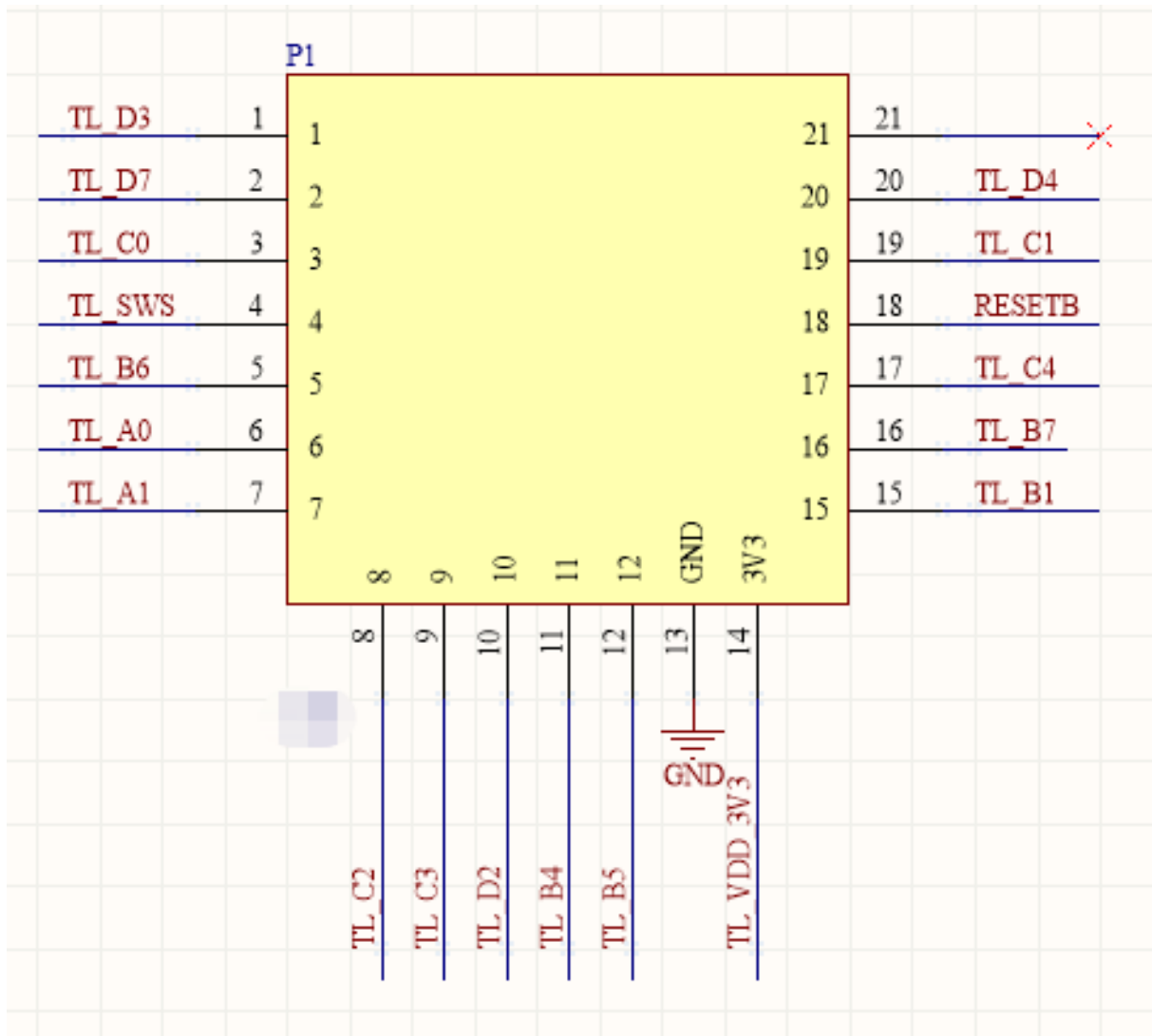

6.4 Diagram of PCB packaging-pin header

ZTU-IPEX can choose SMT placement or pin header plug-in. The dimensions of the plug-in are as follows:

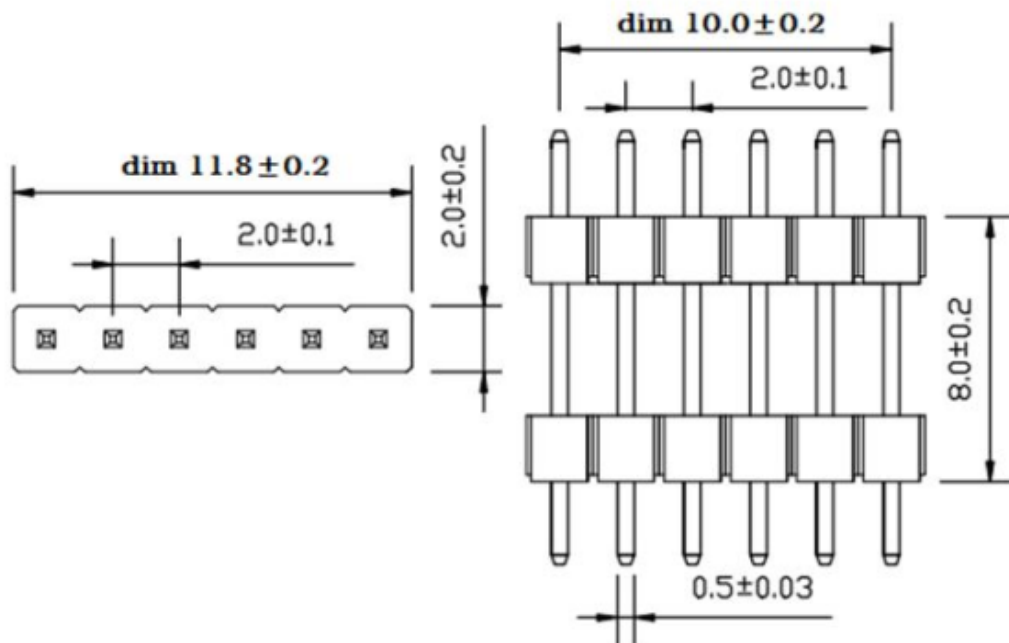

PCB Packaging Diagram-SMT:

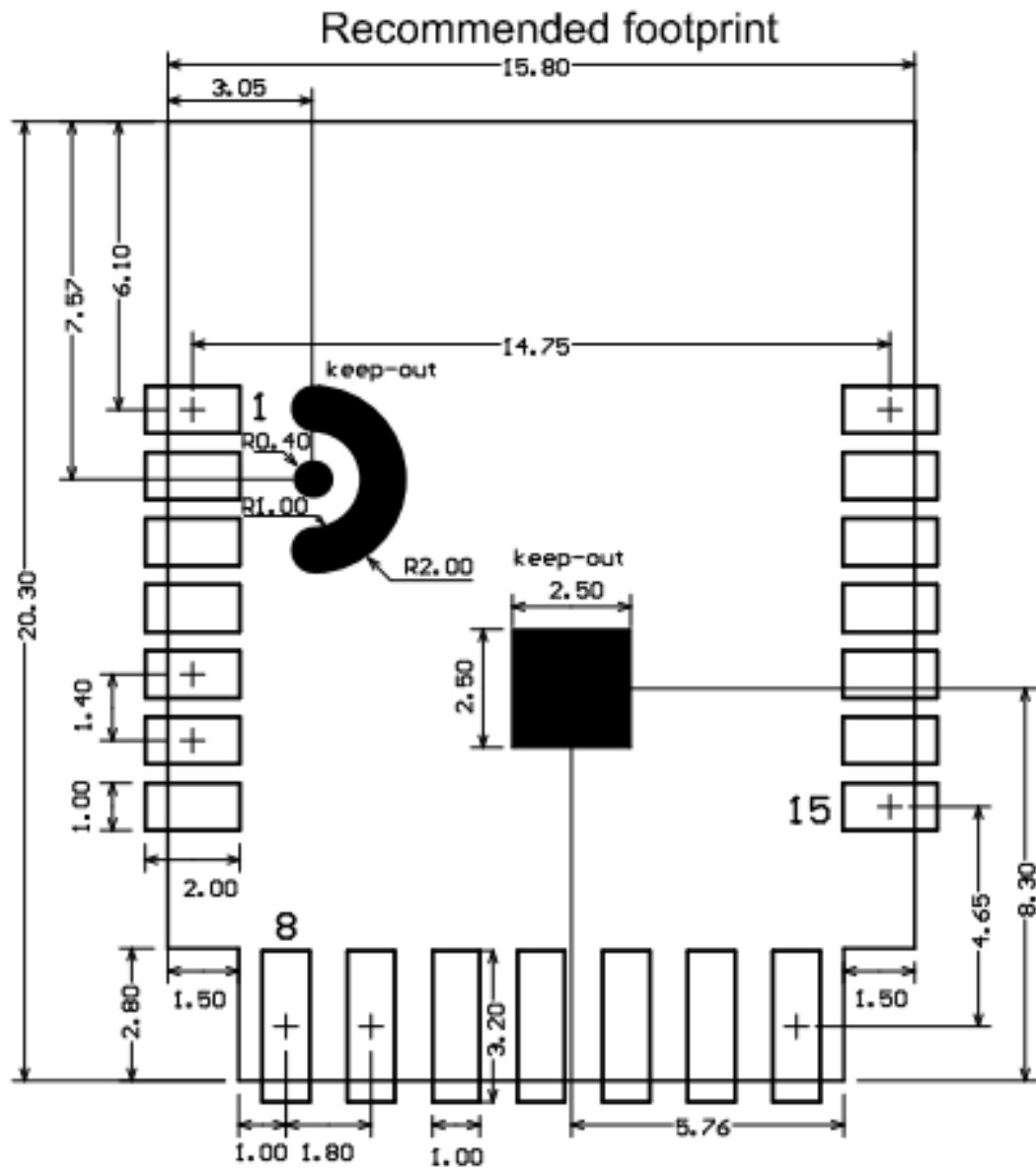

6.5 Production instructions

- The stamp-hole module must be mounted by the SMT machine. After being unpacked, it must be soldered within 24 hours. Otherwise, it must be put into the drying cupboard where the RH is not greater than 10%, or it needs to be packaged under vacuum again and the exposure time needs to be recorded (the total exposure time cannot exceed 168 hours).

- SMT equipment:
 - * Mounter
 - * SPI
 - * Reflow soldering machine
 - * Oven temperature tester
 - * Automated optical inspection (AOI) equipment
- Baking equipment:
 - * Cabinet oven
 - * Anti-static heat-resistant pallets
 - * Anti-static heat-resistant gloves
- Storage conditions for a delivered module are as follows:
 - The moisture-proof bag must be placed in an environment where the temperature is below 40°C and the relative humidity is lower than 90%.
 - The shelf life of a dry-packaged product is 12 months from the date when the product is packaged and sealed.
 - The package contains a humidity indicator card (HIC).

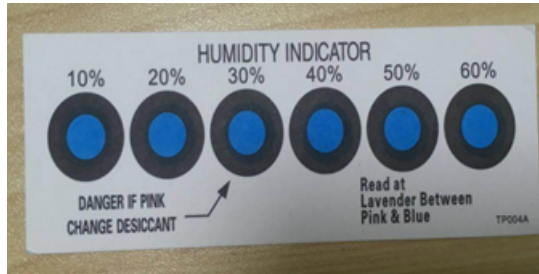

- The module needs to be baked in the following cases:
 - Vacuum packing bag was found to be damaged before being unpacked.
 - There is no humidity indicator card (HIC) in the vacuum packing bag.
 - After being unpacked, 10% and above circles on the HIC become pink.
 - The total exposure time has been more than 168 hours since unpacking.
 - More than 12 months have passed since the sealing date of the bag.
- Baking settings:
 - Temperature: 60°C and $\leq 5\%RH$ for reelizing and 125°C and $\leq 5\%RH$ for palletizing (please use heat-resistant pallet rather than plastic pallet)
 - Time: 48 hours for reelizing and 12 hours for palletizing
 - Alarm temperature: 65°C for reelizing and 135°C for palletizing

- Production ready temperature after natural cooling: < 36°C
 - The number of drying times: 1
 - Re-baking condition: If a module remains unused for 168 hours after being unpacked, it must be baked again. > **Important:** If this batch of modules is not baked within 168 hours, do not use the wave soldering to solder them. Because these modules are 3-level moisture-sensitive components, they are very likely to get damp when exposed outside. In this case, if they are soldered at high temperatures, it may result in component failure or poor soldering.
- In the whole production process, take electrostatic discharge (ESD) protective measures.
 - To guarantee the passing rate, it is recommended that you use the SPI and AOI to monitor the quality of solder paste printing and mounting.

6.6 Recommended oven temperature curve

Perform mounting with the SMT based on the following reflow oven temperature curve. The highest temperature is 245°C. The reflow temperature curve is as below:

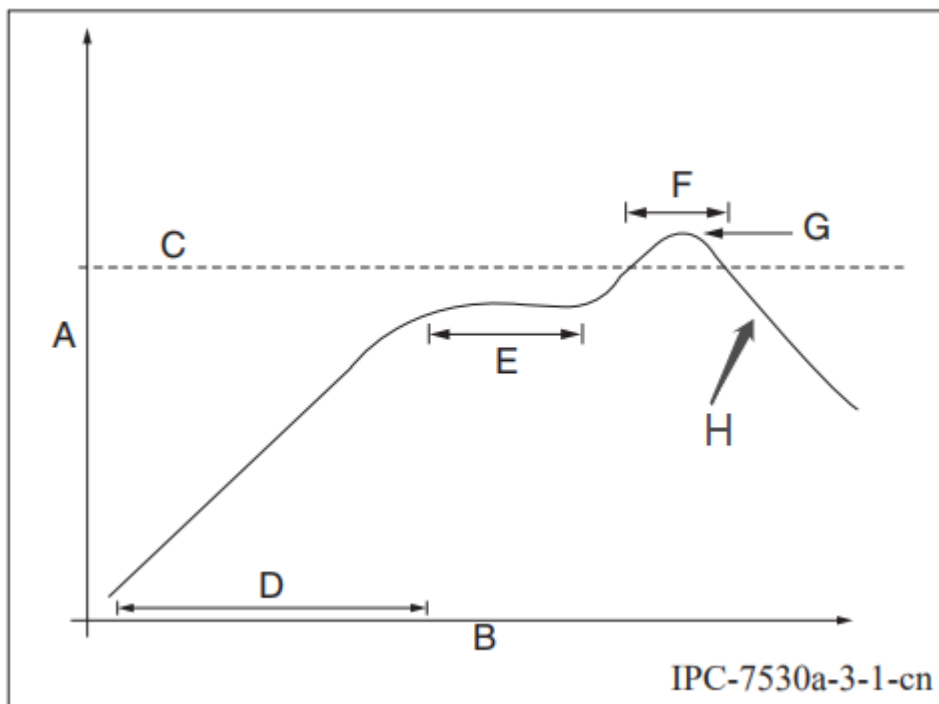

- A: Temperature axis
- B: Time axis
- C: Liquidus temperature: 217 to 220°C
- D: Ramp-up slope: 1 to 3°C/s
- E: Duration of constant temperature: 60 to 120s; the range of constant temperature: 150 to 200°C
- F: Duration above the liquidus: 50 to 70s
- G: Peak temperature: 235 to 245°C
- H: Ramp-down slope: 1 to 4°C/s

Note: The above curve is just an example of the solder paste SAC305. For more details about other solder pastes, please refer to Recommended oven temperature curve in the solder paste specifications.

6.7 Storage conditions



CAUTION
This bag contains
MOISTURE-SENSITIVE DEVICES

LEVEL
3

if Blank, see adjacent
bar code label

1. Calculated shelf life in sealed bag: 12 months at < 40°C and < 90% relative humidity (RH)
2. Peak package body temperature: 260 °C
if Blank, see adjacent bar code label
3. After bag is opened, devices that will be subjected to reflow solder or other high temperature process must
 - a) Mounted within: 168 hrs. of factory conditions
if Blank, see adjacent bar code label
 ≤ 30°C/60%RH, OR
 - b) Stored at <10% RH
4. Devices require bake, before mounting, if:
 - a) Humidity Indicator Card is > 10% when read at 23 ± 5°C
 - b) 3a or 3b not met.
5. If baking is required, devices may be baked for 48 hrs. at 125 ± 5°C

Note: If device containers cannot be subjected to high temperature or shorter bake times are desired, reference IPC/JEDEC J-STD-033 for bake procedure

Bag Seal Date: _____
if Blank, see adjacent bar code label

Note: Level and body temperature defined by IPC/JEDEC J-STD-020

7 MOQ and packaging information

Product number	MOQ (pcs)	Shipping packaging method	The number of modules per reel	The number of reels per carton
ZTU	4000	Tape reel	1000	4

8 Appendix: Statement

FCC Caution: Any changes or modifications not expressly approved by the party responsible for compliance could void the user’s authority to operate this device.

This device complies with Part 15 of the FCC Rules. Operation is subject to the following two conditions: (1) This device may not cause harmful interference, and (2) this device must accept any interference received, including interference that may cause undesired operation.

Note: This device has been tested and found to comply with the limits for a Class B digital device, according to part 15 of the FCC Rules. These limits are designed to provide reasonable protection against harmful interference in a residential installation. This device generates, uses, and can radiate radio frequency energy and, if not installed and used following the instructions, may cause harmful interference to radio communications. However, there is no guarantee that interference will not occur in a particular installation.

If this device does cause harmful interference to radio or television reception, which can be determined by turning the device off and on, the user is encouraged to try to correct the interference by one or more of the following measures:

- Reorient or relocate the receiving antenna.
- Increase the separation between the device and receiver.
- Connect the device into an outlet on a circuit different from that to which the receiver is connected.
- Consult the dealer or an experienced radio/TV technician for help.

Radiation Exposure Statement

This device complies with FCC radiation exposure limits set forth for an uncontrolled

rolled environment. This device should be installed and operated with a minimum distance of 20cm between the radiator and your body.

Important Note

This radio module must not be installed to co-locate and operating simultaneously with other radios in the host system except following FCC multi-transmitter product procedures. Additional testing and device authorization may be required to operate simultaneously with other radios.

The availability of some specific channels and/or operational frequency bands are country-dependent and are firmware programmed at the factory to match the intended destination. The firmware setting is not accessible by the end-user.

The host product manufacturer is responsible for compliance with any other FCC rules that apply to the host not covered by the modular transmitter grant of certification. The final host product still requires Part 15 Subpart B compliance testing with the modular transmitter installed.

The end-user manual shall include all required regulatory information/warnings as shown in this manual, including “This product must be installed and operated with a minimum distance of 20 cm between the radiator and user body”.

This device has got an FCC ID: 2ANDL-ZTU. The end product must be labeled in a visible area with the following: “Contains Transmitter Module FCC ID: 2ANDL-ZTU”.

This device is intended only for OEM integrators under the following conditions:

The antenna must be installed such that 20cm is maintained between the antenna and users, and the transmitter module may not be co-located with any other transmitter or antenna.

As long as the 2 conditions above are met, further transmitter tests will not be required. However, the OEM integrator is still responsible for testing their end-product for any additional compliance requirements required with this module installed.

Declaration of Conformity European Notice

Hereby, Hangzhou Tuya Information Technology Co., Ltd declares that this module product is in compliance with essential requirements and other relevant provisions

of Directive 2014/53/EU,2011/65/EU. A copy of the Declaration of conformity can be found at <https://www.tuya.com>.



This product must not be disposed of as normal household waste, in accordance with the EU directive for waste electrical and electronic equipment (WEEE-2012/19/EU). Instead, it should be disposed of by returning it to the point of sale, or to a municipal recycling collection point.

The device could be used with a separation distance of 20cm to the human body.